

DETAIL A
 SCALE 1 : 4

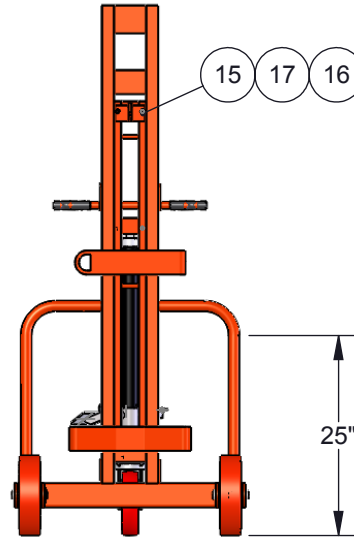
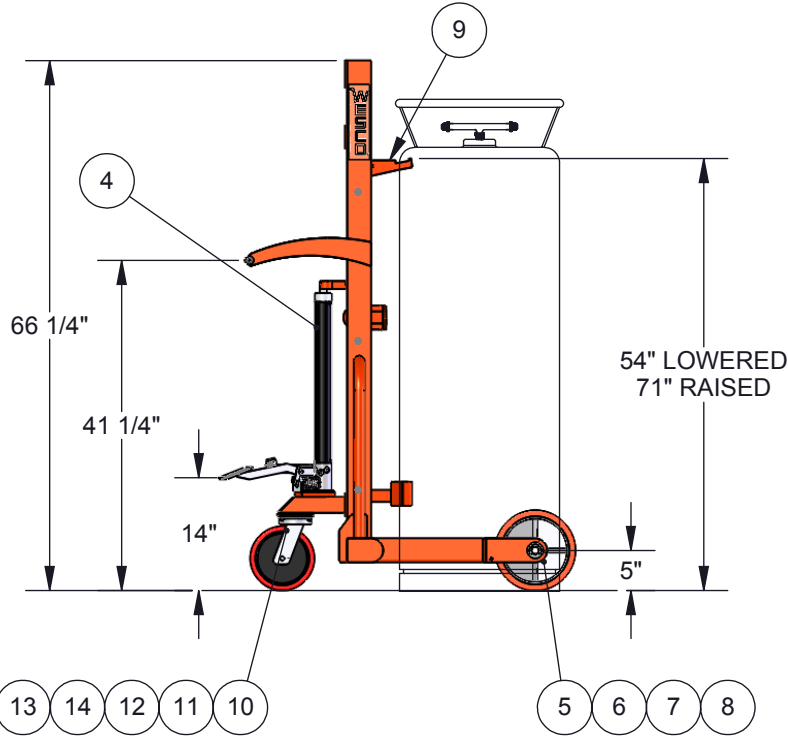

REPLACEMENT PARTS			
ITEM	PART NO.	DESCRIPTION	QTY.
1	100457	RING: RETAINING 1/2", HVY. EXT. BL PHOS	6
2	108941	WASHER: (PLTD) 1OD(1/2ID)x16Ga	12
3	050853	ROLLER: CARRIAGE (DM-1100)	6
4	054980	JACK: ASS'Y (40") HLCC	1
5	053730	WHEEL: 10" x 2-1/2" PPU ON POLY HUB	2
6	053930	AXLE: 1" FRONT WHEEL, LIQUID CYL. CART	2
7	109363	RING: RETAINING "SE"TYPE 1" SHAFT	4
8	108208	FLAT WASHER (1" SAE)	8
9	054958	WELDMENT:HOOK, HLCC	1
10	053732	CASTER: SWIVEL,8" CROWN POLY, TOTAL LOCK	1
11	108175	NUT: HEX (PLTD) 5/16-18	4
12	108149	SCR: HEX HD CAP (PLTD) 5/16-18x1"	4
13	100069	WASHER: FLAT (PLTD) 5/16 SAE	4
14	100170	WASHER: LOCK (PLTD) 5/16 MED SPLIT	4
15	105080	SCR: SCKT HD CAP 3/8-16x1-1/4", BLK	5
16	100642	HEX NUT 3/8-16	5
17	100217	LOCKWASHER 3/8 DIA.	5
* 18	109343	RATCHET: TIE DOWN, CARGO BUCKLE	1

*NOT SHOWN

Specifications:

Capacity: 1000 Lbs
 Lowered Height: 54"
 Raised Height: 71"
 Weight: 198 Lbs

NOTES:

- 10" Polyurethane-tread main load wheels
- 8" Polyurethane-tread total lock swivel caster
- Retractable ratchet strap makes securing load quick and easy
- 3 Wheel design makes maneuvering easy

PROPRIETARY
 THIS DRAWING IN ALL PARTICULARS IS WESCO INDUSTRIAL PRODUCTS INC. PROPERTY. ALL RIGHTS OF DESIGN, INVENTION OR USE OF ARE RESERVED.



Manufacturers of Material Handling Equipment Since 1948
 NORTH WALES, PA 19454 PH: 215-699-7031

	NAME	DATE
DRAWN	DR	08/29/13
CHECKED		
ENG APPR.		

TITLE: **HYDRAULIC LIQUID CYLINDER CART**

PROJECT: **HLCC**

TOLERANCES
 UNLESS OTHERWISE SPECIFIED DIMENSIONS ARE IN INCHES
 FRACTIONAL ± 1/64
 ANGULAR: ±1.5°
 TWO PLACE DECIMAL ±0.01
 THREE PLACE DECIMAL ±0.005

SIZE	DWG. NO.	REV
A	240250	A
SCALE: 1:24	WEIGHT: 198 lb.	SHEET 1 OF 1